

STANDARD TYPE S9D SERIES [150W]

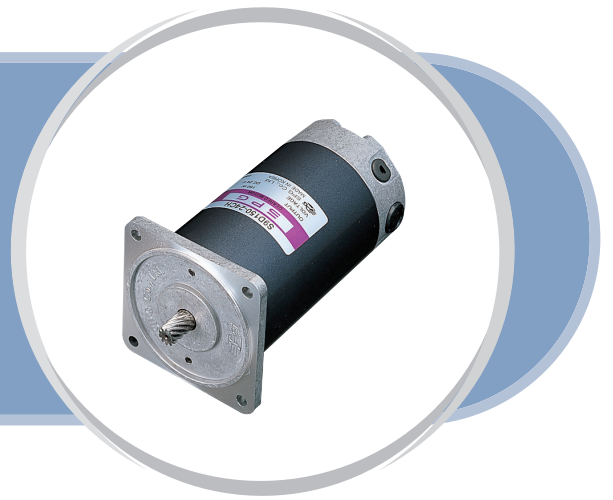

MOTOR DIMENSION

UNIT : mm[inch]

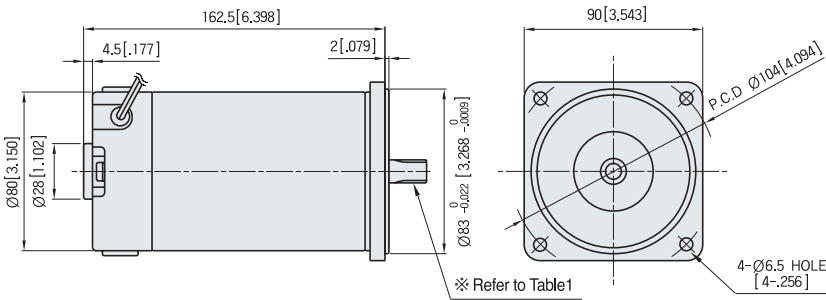

CHARACTERISTIC CURVE

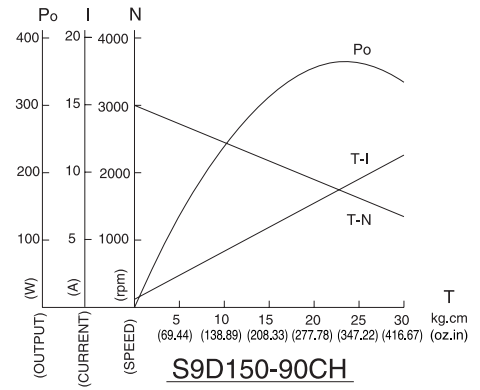

▼ SPEC for output shaft of motor-(Table1)

MODEL	GEARED TYPE	STRAIGHT TYPE	D-CUT TYPE	KEY TYPE
	S9D150-□CH	S9D150-□S	S9D150-□D	S9D150-□K
TYPE OF OUTPUT SHAFT				

CIRCUIT DIAGRAM

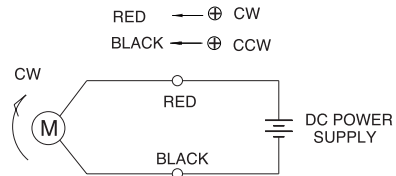

The direction of motor rotation is as viewed from the front shaft end of the motor

MOTOR SPECIFICATION

(Voltage : DC 24V)

Type	Voltage V	Output W	No Load		At Rated Load			Run Duty Hr	Weight Kg	
			Speed RPM	Current(MAX.) A	Speed RPM	Torque	Current A			
S9D150-12□	12	150	3200	3.0	2560	0.559	N·m	20	2000	2.8
						79.1	oz·in			
						5.70	kgf·cm			
S9D150-24□	24	150	3000	2.0	2650	0.539	N·m	8.5	2000	2.8
						76.3	oz·in			
						5.50	kgf·cm			
S9D150-90□	90	150	3000	0.5	2650	0.539	N·m	2.2	2000	2.8
						76.3	oz·in			
						5.50	kgf·cm			

※ Run duty is valued at rated Voltage and No load

GEARED MOTOR SPECIFICATION

UNIT : mm[inch]

▼ GEARED MOTOR ※ MOTOR MODEL : S9D150-□CH
 ※ HEAD MODEL : S9□C3BH-S~S9□C200BH-S

▼ INTER-DECIMAL GEAR HEAD
 ※ MODEL : S9GX10BH-S

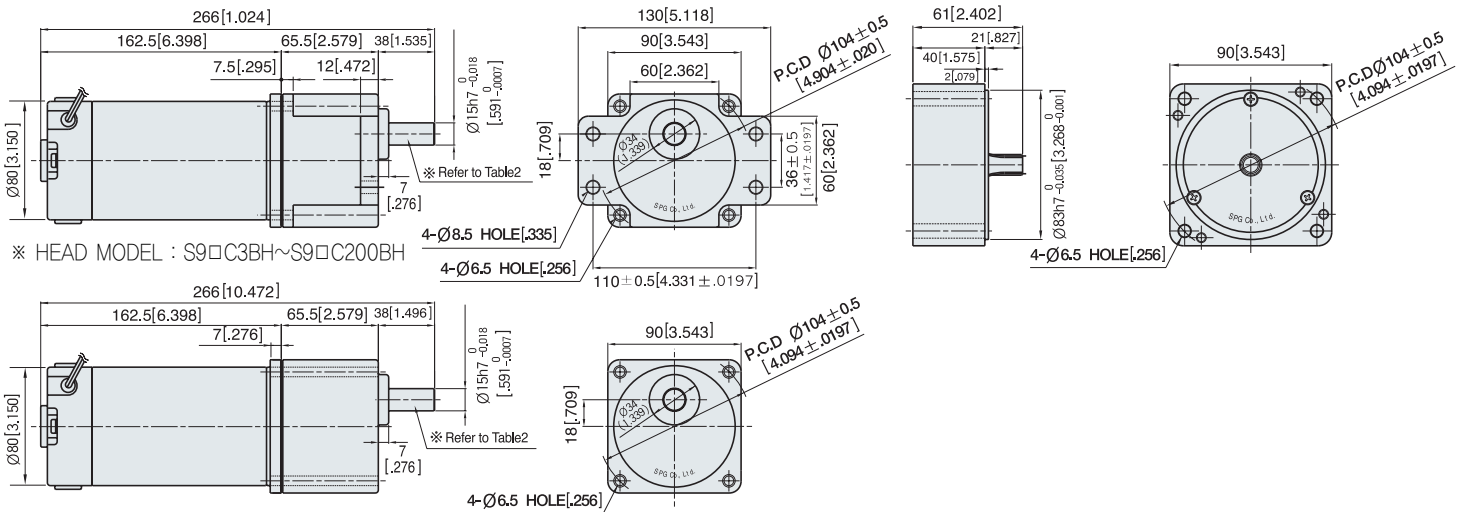

STANDARD TYPE PERMANENT MAGNET DC MOTOR | 28

▼ ※30(40) – (Table1)

PART		WEIGHT:kg(oz)
MOTOR		2.8(98.8)
DECIMAL GEAR HEAD		0.65(22.9)
GEAR HEAD	S9 □ C3BH ~S9 □ C10BH	1.21(42.7)
	S9 □ C12.5BH ~S9 □ C20BH	1.30(45.9)
	S9 □ C25BH ~S9 □ C60BH	1.40(49.4)
	S9 □ C75BH ~S9 □ C200BH	1.45(51.1)

▼ SPEC for output shaft of gearhead-(Table2)

MODEL	TYPES OF OUTPUT SHAFT
STRAIGHT TYPE	
S9SC3BH ~S9SC200BH	
D-CUT TYPE	
S9DC3BH ~S9DC200BH	
KEY TYPE	
S9KC3BH ~S9KC200BH	

▼ KEY SPEC

GEAR HEAD	MOTOR

GEAR HEAD RATED LOAD

S9D150-90CH

MODEL	GEAR RATIO	3	3.6	5	6	7.5	9	10	12.5	15	18	20	25	30	36	40	50	60	75	90	100	120	150	180	200
		No Load rpm	1000	833	600	500	400	333	300	240	200	167	150	120	100	83	75	60	50	40	33	30	25	20	17
S9KC□ BH S9KC□ BH-S	N-m	1,31	1,57	2,18	2,62	3,27	3,93	4,37	4,91	5,89	7,07	7,86	8,84	10,61	12,73	14,15	17,68	19,60	19,60	19,60	19,60	19,60	19,60	19,60	19,60
	oz-in	185.5	222.6	309.1	370.9	463.7	556.4	618.2	695.5	834.6	1001.5	1112.8	1251.9	1502.3	1802.7	2003.0	2503.8	2775.4	2775.4	2775.4	2775.4	2775.4	2775.4	2775.4	2775.4
	kgf·cm	13.4	16.0	22.3	26.7	33.4	40.1	44.6	50.1	60.1	72.2	80.2	90.2	108.3	129.9	144.3	180.4	200.0	200.0	200.0	200.0	200.0	200.0	200.0	200.0

- The code in of gearhead model is for gear ratio
- It is the permissible torque of the assembled motor and gearhead
 The permissible torque of the combination of the regular gearhead and the inter-decimal gearhead is 30kgf·cm.
- color indicates that the output shaft of the geared motor rotates in the same direction as the output shaft of the motor.
 Others indicate rotation in the opposite direction.
- No Load rpm equals Motor no load rpm divided by gear ratio. The actual rotation speed is less 2-20% than the displayed value according to the load
- There is no marked the 'L' code for it is an exclusive use.

21C, for World geared motor!



GEARED MOTOR SPECIFICATION

UNIT : mm[inch]

▼ GEARED MOTOR ※ MOTOR MODEL : S9D150-□CH
 ※ HEAD MODEL : S9□D3B~S9□D200B

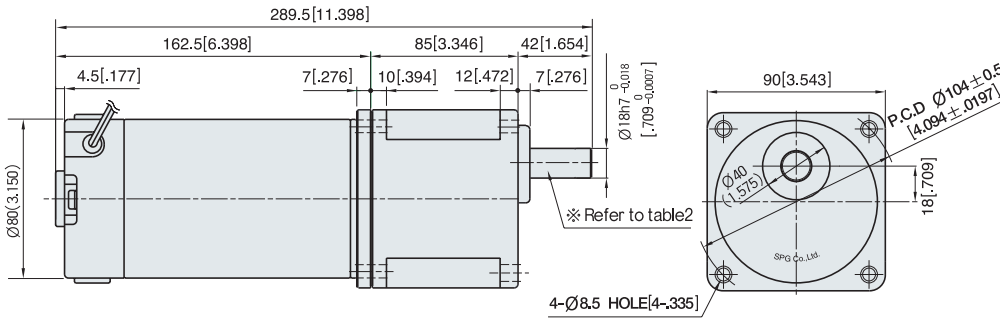

▼ ※30(40) – (Table1)

PART		WEIGHT:kg(oz)
MOTOR		2.2(77.6)
GEAR HEAD	S9 □ D3B ~S9 □ D10B	1.65(58.2)
	S9 □ D12.5B ~S9 □ D20B	1.80(63.5)
	S9 □ D25B ~S9 □ D60B	1.90(67.0)
	S9 □ D75B ~S9 □ D200B	1.95(68.8)

▼ SPEC for output shaft of gearhead-(Table2)

MODEL	TYPES OF OUTPUT SHAFT
STRAIGHT TYPE	
S9SD3B ~S9SD200B	
D-CUT TYPE	
S9DD3B ~S9DD200B	
KEY TYPE	
S9KD3B ~S9KD200B	

▼ KEY SPEC

GEAR HEAD	MOTOR

GEAR HEAD RATED LOAD

S9D150-90HH

MODEL	GEAR RATIO	3	3.6	5	6	7.5	9	10	12.5	15	18	20	25	30	36	40	50	60	75	90	100	120	150	180	200
		No Load rpm	1000	833	600	500	400	333	300	240	200	167	150	120	100	83	75	60	50	40	33	30	25	20	17
S9KD□ B S9KD□ B-S	N-m	1.31	1.57	2.18	2.62	3.27	3.93	4.37	4.91	5.89	7.07	7.86	8.84	10.61	12.73	14.15	17.68	21.22	23.87	28.64	29.40	29.40	29.40	29.40	29.40
	oz-in	85.5	222.6	309.1	370.9	463.7	556.4	618.2	695.5	834.6	1001.5	1112.8	1251.9	1502.3	1802.7	2003.0	2503.8	3004.5	3380.1	4056.1	4163.0	4163.0	4163.0	4163.0	4163.0
	kgf·cm	13.4	16.0	22.3	26.7	33.4	40.1	44.6	50.1	60.1	72.2	80.2	90.2	108.3	129.9	144.3	180.4	216.5	243.6	292.3	300.0	300.0	300.0	300.0	300.0

- The code in ■ of gearhead model is for gear ratio
- It is the permissible torque of the assembled motor and gearhead
 The permissible torque of the combination of the regular gearhead and the inter-decimal gearhead is 30kgf·cm
- ■ color indicates that the output shaft of the geared motor rotates in the same direction as the output shaft of the motor.
 Others indicate rotation in the opposite direction.
- No Load rpm equals Motor no load rpm divided by gear ratio. The actual rotation speed is less 2-20% than the displayed value according to the load
- There is no marked the 'L' code for it is an exclusive use.